

Data Sheet | Item Number: 750-377

Fieldbus Coupler PROFINET IO; 3rd Generation; ECO Advanced

<https://www.wago.com/750-377>

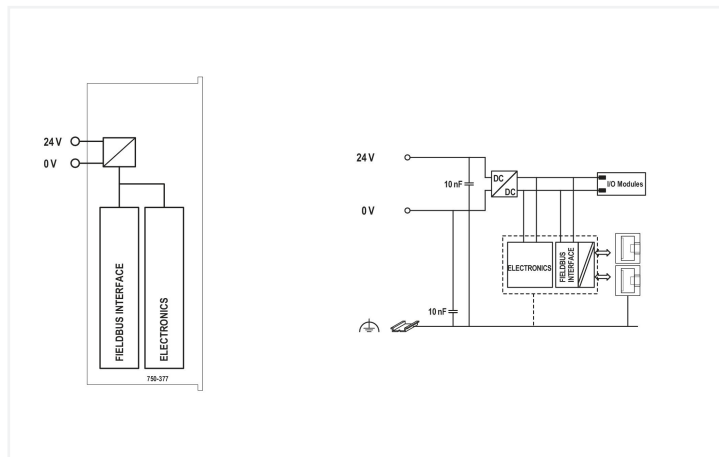

Color: light gray

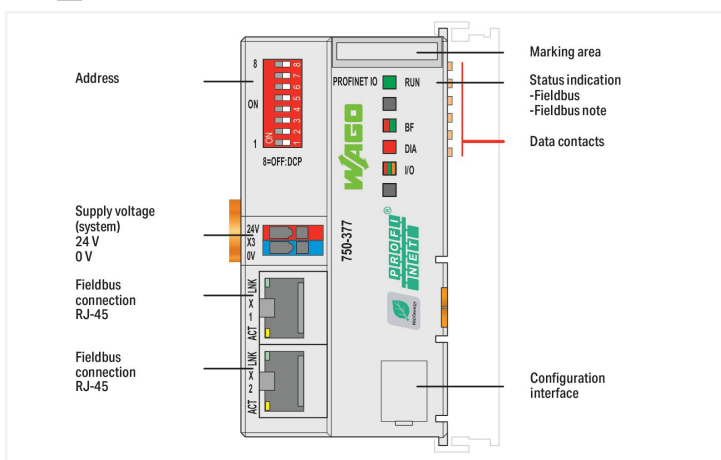

This fieldbus coupler connects the WAGO I/O System 750 to PROFINET IO (open, real-time Industrial ETHERNET automation standard). The coupler identifies the connected I/O modules and creates local process images for one I/O controller and one I/O supervisor according to preset configurations. This process image may include a mixed arrangement of analog (word-by-word data transfer) or complex modules and digital (bit-by-bit data transfer) modules. The fieldbus coupler operates as an I/O device in the network. It features an integrated 2-port switch, simplifying the creation of a line structure without additional network components. The device name can be assigned via DCP protocol or a default name can be instantiated via DIP switch.

Technical data	
Communication	PROFINET IO
Device-specific	Supported profiles: PROFIsafe V2, PROFINergy V1.0; ID code: Vendor ID: 0x011D; Device ID: 0x02EE; Module ID: 0x01000177 (firmware version 01, 02), 0x02000177 (from firmware version 03)
Baud rate	10/100 Mbit/s (10 Mbit/s (ETHERNET protocols), 100 Mbit/s full duplex (PROFINET IO))
Bus segment length (max.)	100 m
Transmission medium	Twisted pair S-UTP; 100 Ω; Cat. 5
Number of modules per node (max.)	64
Input and output process image (fieldbus) max.	256 bytes/256 bytes
Supply voltage (system)	24 VDC (-25 ... +30 %); via pluggable connector
Current consumption (5 V system supply)	450 mA
Total current (system supply)	700 mA
Input current (typ.) at nominal load (24 V)	280 mA
Power supply efficiency (typ.) at nominal load (24 V)	90 %
Isolation	500 V system/field

Connection data

Connection technology: communication/fieldbus	PROFINET IO: 2 x RJ-45
Connection technology: system supply	2 x CAGE CLAMP®
Connection technology: device configuration	1 x Male connector; 4-pole
Connection type 1	System supply
Solid conductor	0.08 ... 1.5 mm ² / 28 ... 14 AWG
Fine-stranded conductor	0.08 ... 1.5 mm ² / 28 ... 14 AWG
Strip length	5 ... 6 mm / 0.2 ... 0.24 inches

Physical data

Width	49.5 mm / 1.949 inches
Height	96.8 mm / 3.811 inches
Depth	71.9 mm / 2.831 inches
Depth from upper-edge of DIN-rail	64.7 mm / 2.547 inches

Mechanical Data

Mounting type	DIN-35 rail
---------------	-------------

Material Data

Color	light gray
Housing material	Polycarbonate; polyamide 6.6
Fire load	1.406 MJ
Weight	107.1 g
Conformity marking	CE

Environmental requirements

Ambient temperature (operation)	0 ... +55 °C
Surrounding air temperature (storage)	-25 ... +85 °C
Protection type	IP20
Pollution degree	2 per IEC 61131-2
Operating altitude	0 ... 2000 m / 0 ... 6562 ft
Mounting position	horizontal (standing/lying); vertical
Relative humidity (without condensation)	95 %
Vibration resistance	4g per IEC 60068-2-6
Shock resistance	15g per IEC 60068-2-27
EMC immunity to interference	per EN 61000-6-2, marine applications
EMC emission of interference	per EN 61000-6-3, marine applications
Exposure to pollutants	per IEC 60068-2-42 and IEC 60068-2-43
Permissible H ₂ S contaminant concentration at a relative humidity 75 %	10 ppm
Permissible SO ₂ contaminant concentration at a relative humidity 75 %	25 ppm

Commercial data

Product Group	15 (I/O System)
eCl@ss 10.0	27-24-26-07
eCl@ss 9.0	27-24-26-07
ETIM 8.0	EC001603
ETIM 7.0	EC001603
PU (SPU)	1 pcs
Packaging type	Box
Country of origin	DE
GTIN	4050821687443
Customs tariff number	85176200000

Subject to changes. Please also observe the further product documentation!

Current addresses can be found at: www.wago.com